

# **Procedures to file a request to the DKPTO for Patent Prosecution Highway Pilot Program between the DKPTO and the JPO**

## **Request to the DKPTO**

**[0001]** An applicant should file a request for accelerated examination under the Patent Prosecution Highway (PPH) to the DKPTO by submitting a letter requesting accelerated examination under the PPH accompanied by the relevant supporting documents. The requirements for an application to the DKPTO for accelerated examination under the PPH are given in the following section. Relevant supporting documentation is discussed in a later section (paragraphs [0003]-[0005]) as is the general DKPTO application procedure envisaged at this time (paragraph [0006]).

## **Requirements for requesting accelerated examination under the PPH pilot program at the DKPTO**

**[0002]** There are four requirements for requesting accelerated examination under the PPH pilot program at the DKPTO. These are:

- a) ***The DKPTO application (including PCT national phase applications) is:***
- (i) an application which validly claims priority under the Paris Convention to the JPO application(s) (examples are provided in Annex I, figure A, B, H I, J and K) , or
  - (ii) a PCT national phase application without priority claim (direct PCT applications) (examples are provided in Annex I, figure L), or
  - (iii) an application which validly claims priority under the Paris Convention to the PCT application(s) without priority claim (examples are provided in Annex I, figure M, N and O).

A DKPTO application which validly claims priority to multiple JPO or PCT applications, or which is a divisional application validly based on the originally filed application that is included in (i) to (iii) above, is also eligible.

- b) ***At least one corresponding JPO application has one or more claims that have been determined to be patentable by the JPO.***

Claims clearly identified to be patentable by the JPO in the latest office action at examination stage can form the basis of a request for an accelerated examination under the PPH pilot program. This is the case even though the JPO has not yet granted a patent for those claims if the JPO examiner has added the following routine expression in the “notice of reason for refusal”:

*“At present for invention concerning Claim\*, no reason for refusal is found. Any subsequently identified reasons for rejection will be notified accordingly.”*

c) ***All claims in the DKPTO application for accelerated examination under the PPH must sufficiently correspond to one or more of those claims indicated as patentable in the JPO.***

Claims shall be considered to sufficiently correspond where the claims are of the same or similar scope such that the claims have a common technical feature which makes the claims patentable over the prior art in the corresponding JPO application.

In this regard, claims of the DKPTO which contains additional technical features compared to the claims that the JPO have found patentable will be considered to sufficiently correspond to the JPO claims.

Where amended claims have been determined to be patentable by the JPO, the claims of the DKPTO application should be such that they correspond to the amended claims of the JPO application. Claims of the DKPTO application which are appended to earlier claims of the DKPTO application corresponding to claims that are indicated as patentable by the JPO will also be considered where such claims fall within the scope of the claims indicated as patentable by the JPO.

d) ***The DKPTO has not yet issued a communication stating an intention to grant.***

The heading for such a communication will either be “Berigtigelse af bilag” or “Godkendelse”.

## **Required documents for accelerated examination under the PPH pilot program at the DKPTO**

**[0003] The following documentation will be needed to support a request for accelerated examination under the PPH pilot program at the DKPTO:**

a) ***a copy of the office action(s) relating to the corresponding JPO application(s) and a translation hereof.***

No paper copy and corresponding translation of the office actions need be supplied if the office actions are available on AIPN<sup>1</sup>, as machine translation is available to the examiner via AIPN.

The term “office actions” is here used about the correspondence sent to the applicant or the applicant’s representative from the JPO examiner. Translations can be filed in either Danish or English and machine translations are admissible. If the DKPTO examiner is not able to understand the translated office actions to a sufficient extent, the examiner can request the applicant to submit (or resubmit) translations.

---

<sup>1</sup> AIPN is a network between patent offices which provides JPO’s file wrapper information. Applicants do not have access to AIPN, but if you want to know whether information about your application is available on the AIPN, please ask the JPO (PA2260@jpo.go.jp).

b) *a copy of the claims determined to be patentable by the JPO - including any subsequent amended claims found to be patentable by the JPO - and translations of the claims found to be patentable by the JPO.*

Both Danish and English are acceptable translation languages. The terms described above in section [0003]a regarding the occasions where the applicant will not have to submit copies and translations - and regarding machine translations - also apply to this requirement b.

c) *a completed claim correspondence table showing the relationship between the claims of the DKPTO application for accelerated examination under the PPH and the claims of the corresponding JPO application considered patentable by the JPO.*

Sufficient correspondence of claims occurs where the claims are of the same or similar scope as defined above in section [0002]c.

Where the claims applied for at the DKPTO are literal translations of the claims which the JPO has determined to be patentable, it will be sufficient to write “they are the same” in the table of correspondence. When the claims applied for at the DKPTO are not literal translations, it will be necessary to explain why there is a sufficient correspondence of each claim based on the criteria set out in section [0002]c above.

d) *a copy of the references cited by the JPO examiner.*

If the references are patent documents, it will not be necessary to submit these documents, as they will usually be available to the DKPTO. If the DKPTO does not have access to the relevant patent documents, the applicant must submit these documents at the request of the DKPTO. Non-patent literature must always be submitted.

Submission of translations of the references is not required. However, applicants will be free to file translations as part of the supporting documentation when initially requesting accelerated examination under the PPH to allow prompt consideration of the citations if they so desire.

[0004] The applicant is required to complete a form for requesting accelerated examination under the PPH pilot program (as given in Annex II) which will be available for download from the DKPTO website. The form must be sent to the DKPTO along with a letter requesting acceleration under the PPH and the relevant supporting documentation.

[0005] The applicant need not provide further copies of documentation if they have already submitted the documents noted above to the DKPTO through simultaneous or past procedures.

## **Procedure for accelerated examination under the PPH pilot program at the DKPTO**

[0006] The applicant files a letter requesting accelerated examination under the PPH pilot program to the DKPTO, including the relevant supporting documents and a completed request form. The PPH administrator will consider the request and if all requirements are met

the PPH administrator will send an appropriate message to the relevant examining group. The DKPTO's patent examiners will conduct the accelerated examinations.

Annex I

**A** A case meeting requirement a(i)  
- Paris route -

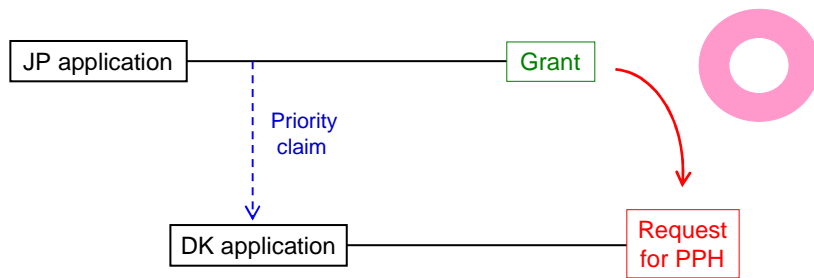

**B** A case meeting requirement a(i)  
- PCT route -

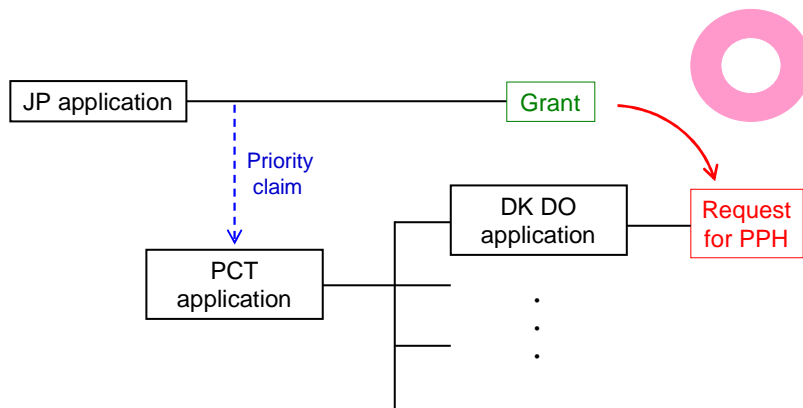

C

### A case not meeting requirement a

- Paris route, but the first application is from the third country -

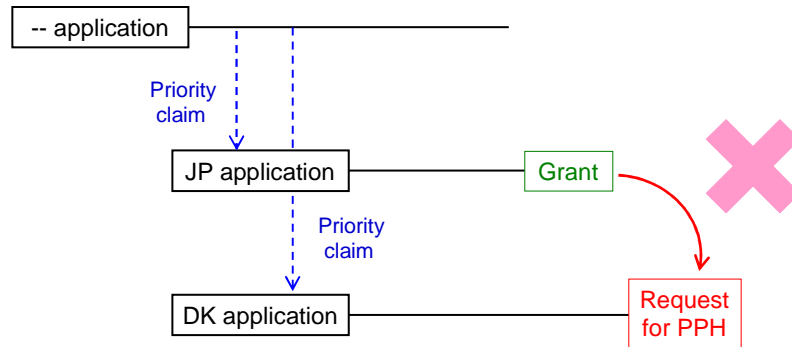

-- : NOT PPH participating country

D

### A case not meeting requirement a

- PCT route, but the first application is from the third country -

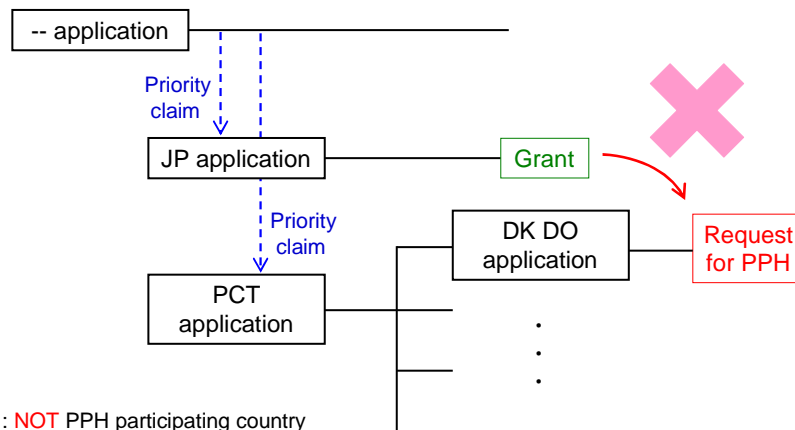

-- : NOT PPH participating country

**E** A case not meeting requirement b  
- Search report -

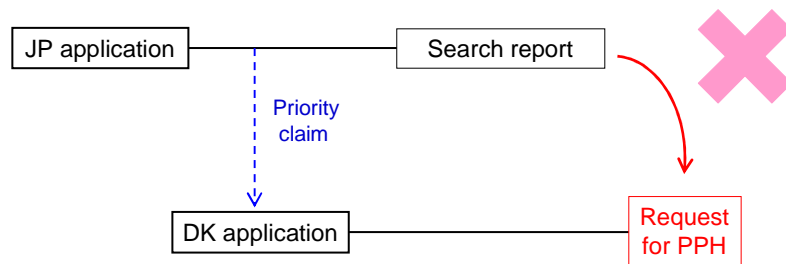

**F** A case not meeting requirement b  
- ISR, ISO -

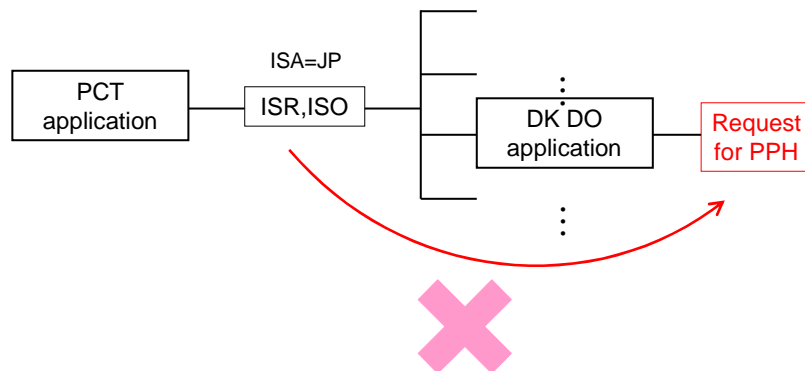

G

### A case not meeting requirement d

- Decision to grant a patent has issued before a request for PPH -

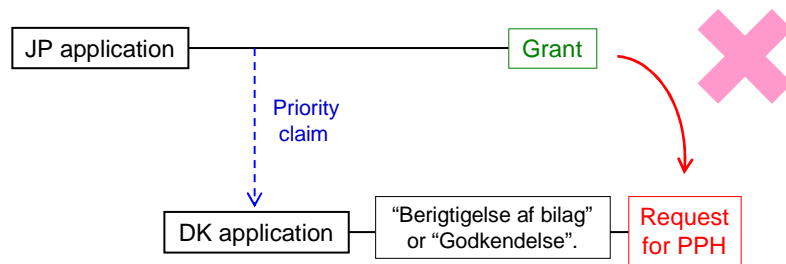

H

### A case meeting requirement a(i)

- Paris route & Complex priority -

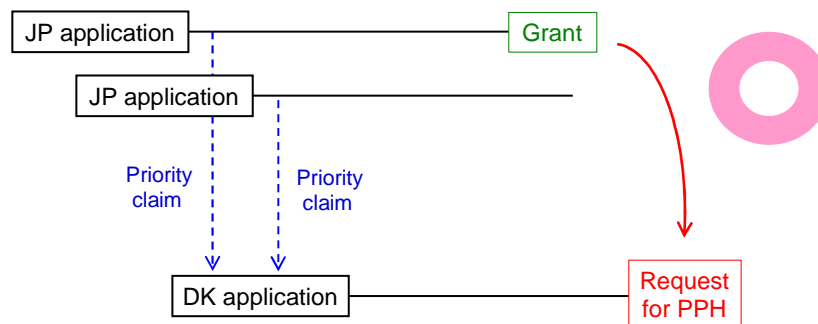

I

A case meeting requirement a(i)  
- Paris route & Internal priority -

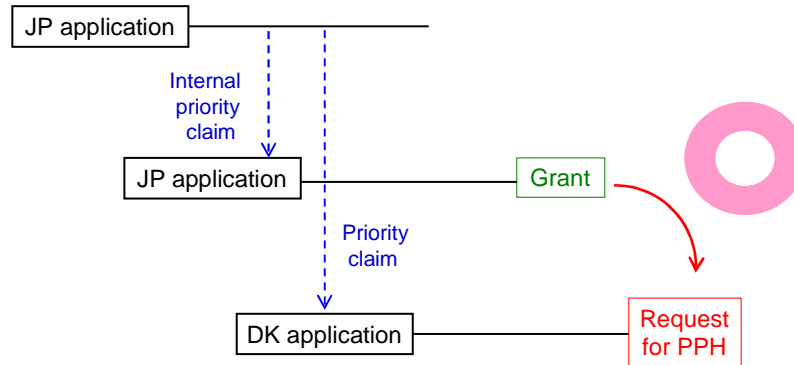

J

A case meeting requirement a(i)  
- Paris route & divisional application -

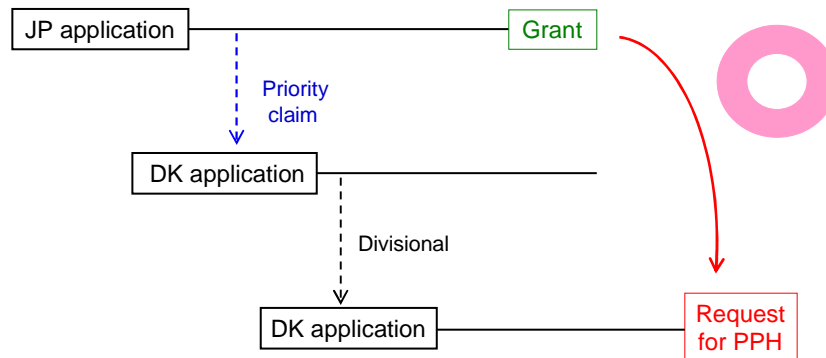

K

A case meeting requirement a(i)  
- PCT route -

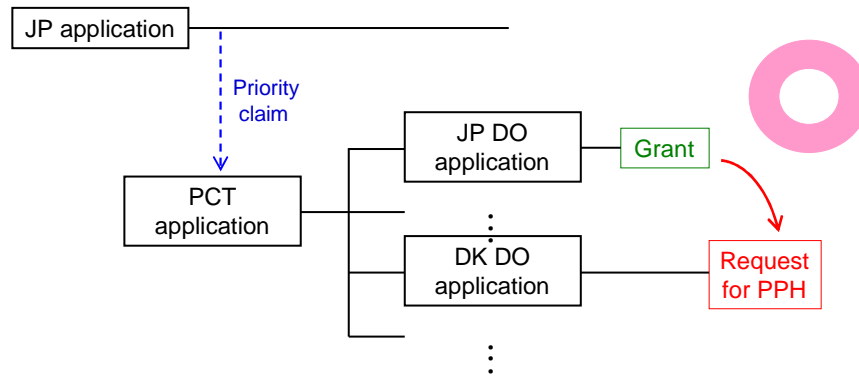

L

A case meeting requirement a(ii)  
- Direct PCT route -

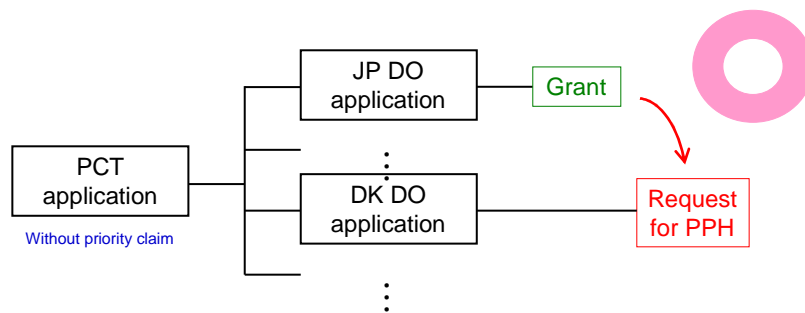

M

A case meeting requirement a(iii)  
- Direct PCT & Paris route -

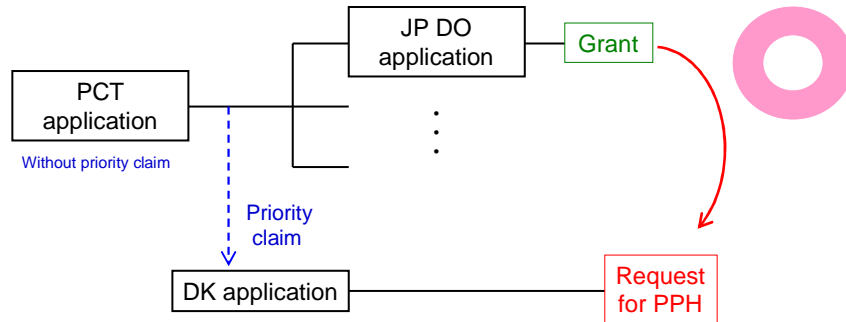

N

A case meeting requirement a(iii)  
- Direct PCT & PCT route -

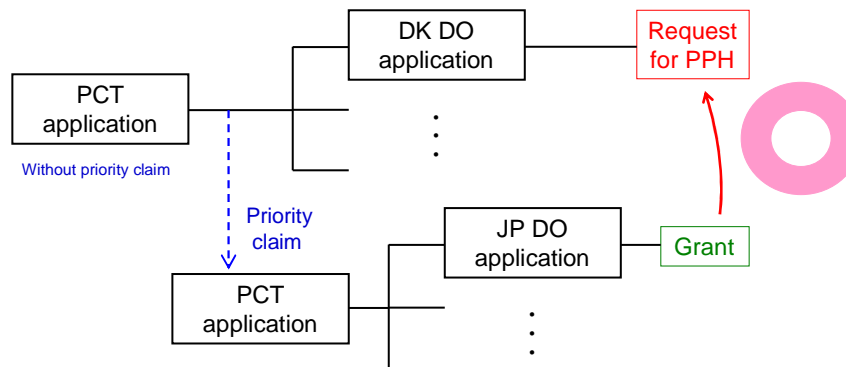

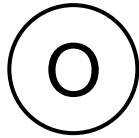

A case meeting requirement a(iii)  
- Direct PCT & PCT route -

